



## ASSEMBLY INSTRUCTION

### ORWELL 3 SEATER CHAISE

ITEM CODE 64930

Imported by Amart Furniture Pty Ltd, Qld, Brisbane Australia.

For any assistance with assembly or for missing parts please phone Amart Furniture, Customer Service Free call 1800 351 084

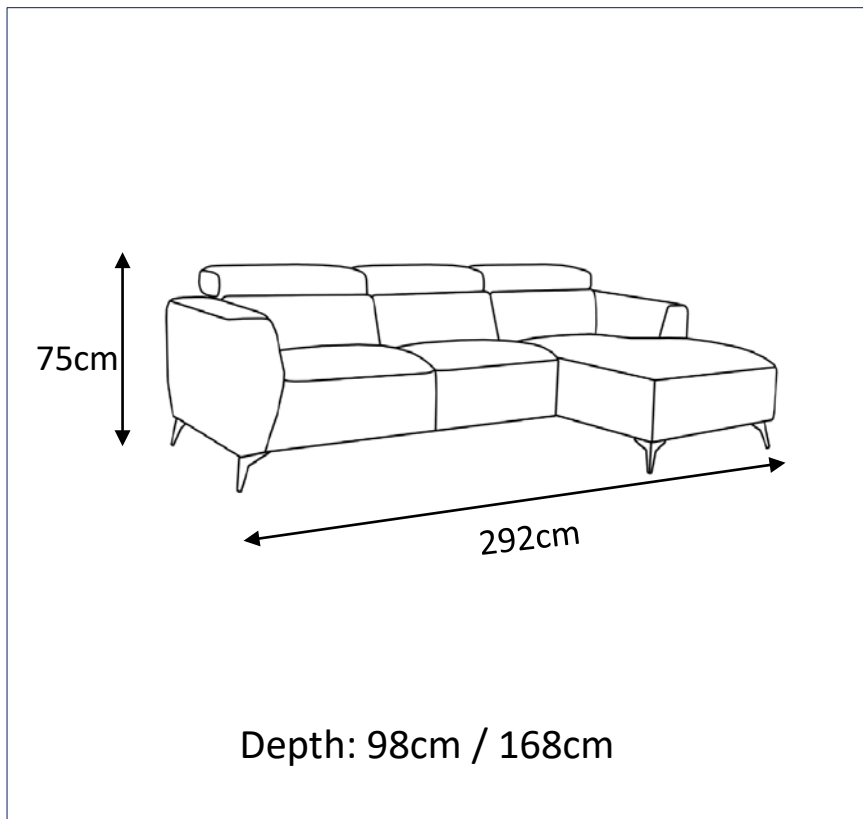



Imported by Amart Furniture Pty Ltd, Qld, Brisbane Australia.

For any assistance with assembly or for missing parts please phone Amart Furniture, Customer Service Free call 1800 351 084

## PRE-ASSEMBLY PREPARATION

### Before you start:

1. Choose a clean, level, spacious assembly area. Avoid hard surfaces that may damage the product
2. Take care when lifting. Product should be assembled as near as possible to the point of use
3. Ensure that you have all required contents for complete assembly
4. Always read the assembly instructions carefully before beginning assembly.
5. Keep all hardware parts and packaging out of reach of small children.
6. Do not over tighten the screws and bolts as this may damage the threads

	
ALLOW 20 MINUTES	2 PEOPLE REQUIRED
	
ADDITIONAL TOOLS REQUIRED	



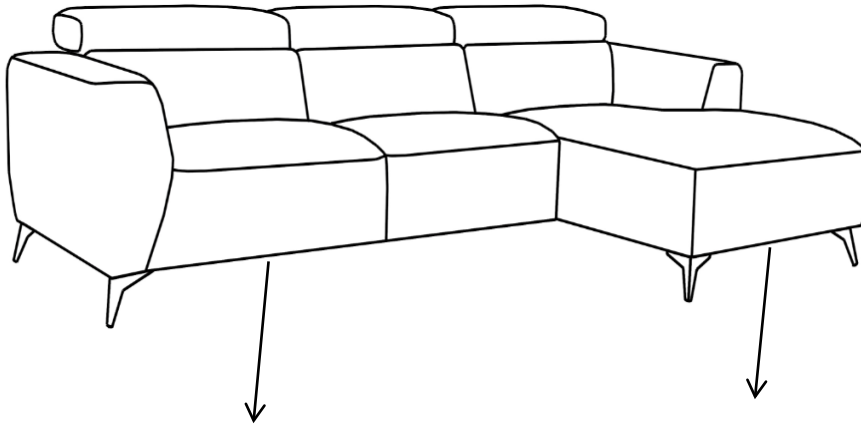

# PARTS LIST







**PART II**

**PART I**

## Hardware

<i>HARDWARE LIST</i>			
	<i>DESCRIPTION</i>		<i>QTY</i>
<i>A</i>	Inclined Sofa Legs		4PCS
<i>B</i>	Bolt	M10x45 	8PCS
<i>C</i>	Allen Key	M10 	1PC
<i>D</i>	Support Leg		1PCS

**PART I**

<i>HARDWARE LIST</i>			
	<i>DESCRIPTION</i>		<i>QTY</i>
<i>A</i>	Inclined Sofa Legs		5 PCS
<i>B</i>	Bolt	M10x45 	10PCS
<i>C</i>	Allen Key	M10 	1PC
<i>D</i>	Support Leg		1PCS

**PART II**

PLEASE TAKE NOTE:  
PIECES REQUIRE FOR ASSEMBLY ARE LOCATED INSIDE THE DUST  
COVER UNDERNEATH SOFA

## Step 1

With 2 people carefully turn sofa onto its front on a piece of cardboard or sheet to protect fabric.

DETAILS (1) - Align base plate of each foot (A) with the pre-threaded holes in the undersides of the sofa as shown in the below diagram.

Insert Bolt (B) and tighten by turning clockwise using Allen key (C).

DETAILS (2) – Insert the thread of the support leg (D) into the corresponding support leg hole.

### PART I

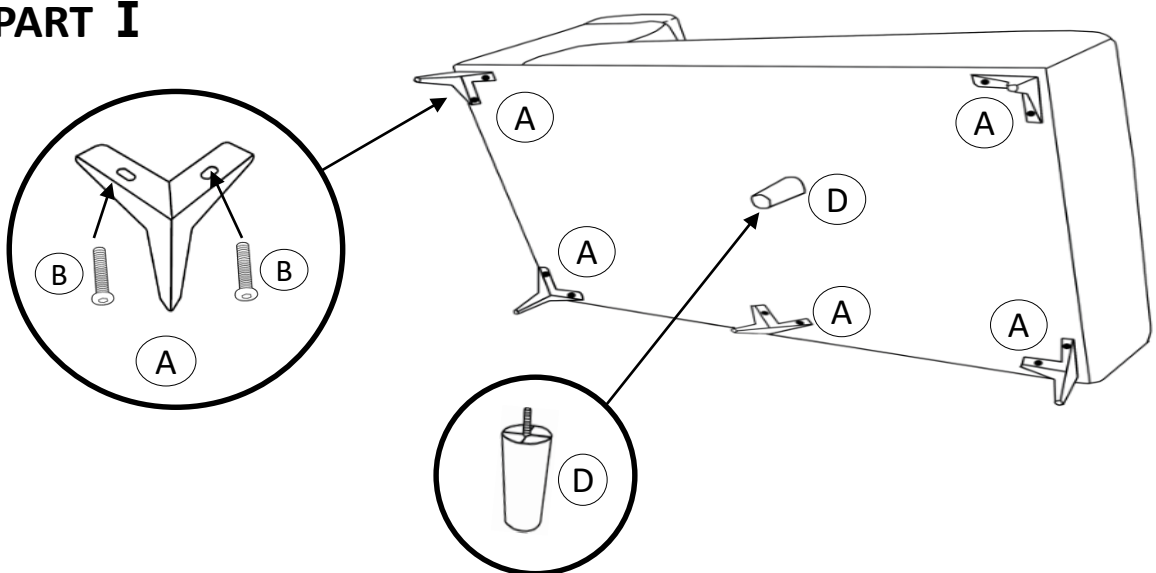

## Step 2 PART I ASSEMBLY COMPLETED

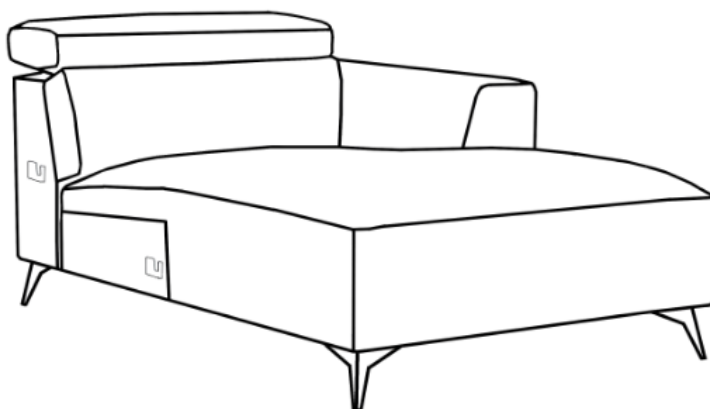

## Step 3

With 2 people carefully turn sofa onto its front on a piece of cardboard or sheet to protect fabric.

DETAILS (1) - Align base plate of each foot (A) with the pre-threaded holes in the undersides of the sofa as shown in the below diagram.

Insert Bolt (B) and tighten by turning clockwise using Allen key (C).

DETAILS (2) – Insert the thread of the support leg (D) into the corresponding support leg hole.

### PART II

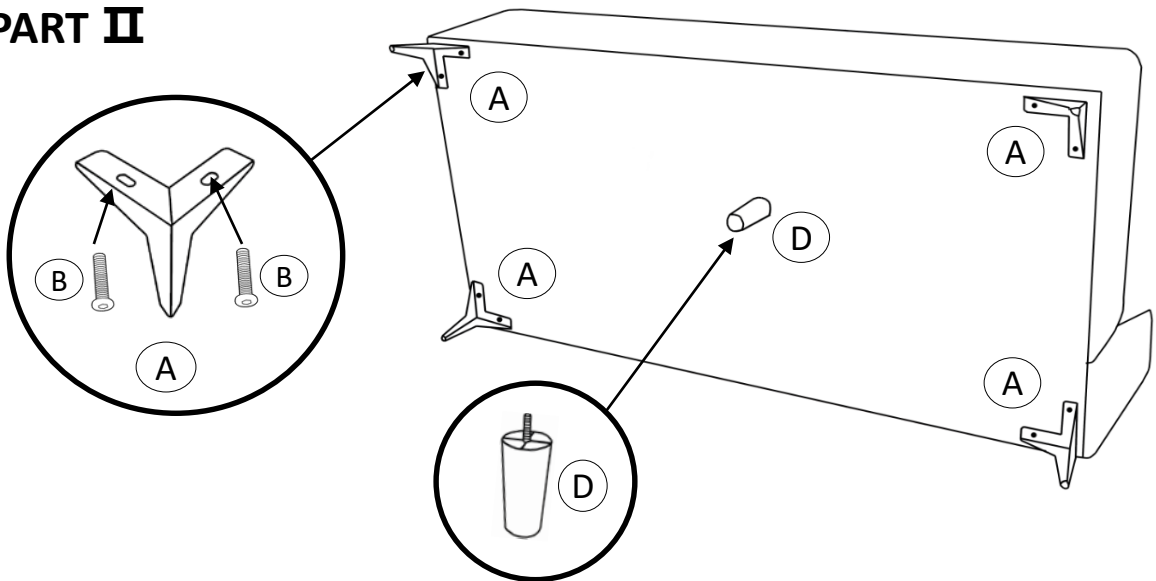

## Step 4 PART II ASSEMBLY COMPLETED

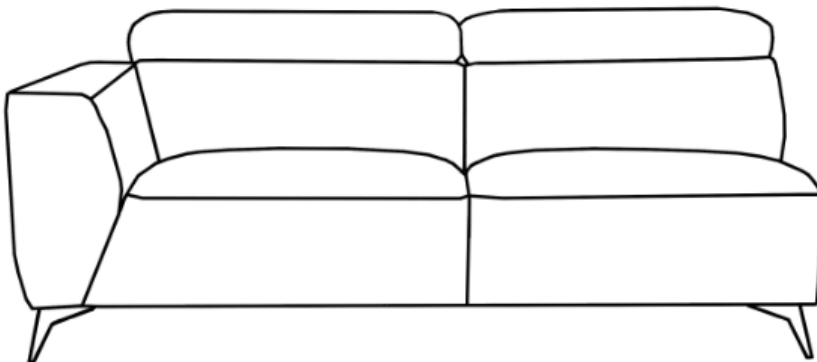

## Step 5 ASSEMBLY COMPLETED

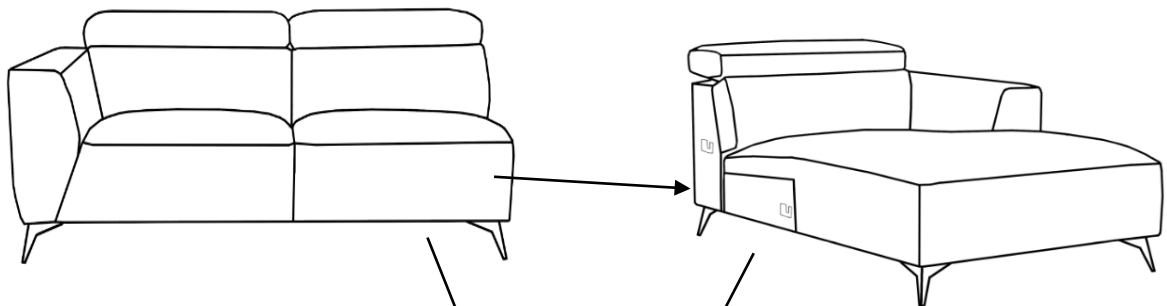

PART II

PART I

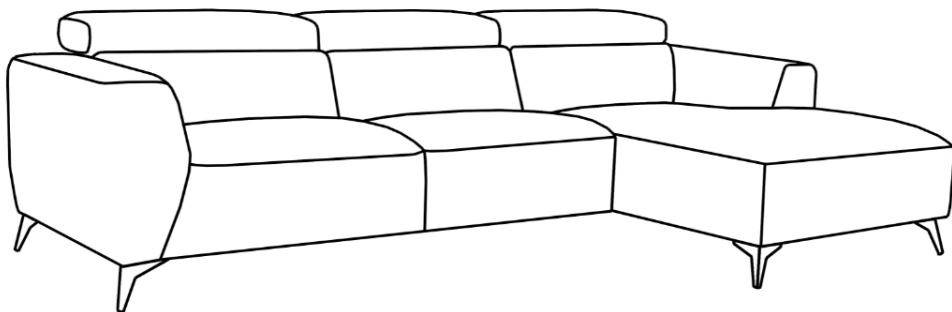
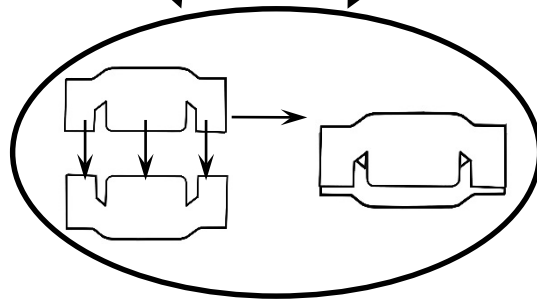

PART II

PART I

**IMPORTANT:**  
PLEASE ENSURE FEET ARE TIGHTENED SECURELY BEFORE USE!

## CARE LABEL

### FABRIC CARE

**REGULAR CARE:** PROTECT FROM DIRECT SUNLIGHT.  
VACUUM REGULARLY USING LOW SUCTION.  
ROTATE REVERSIBLE CUSHIONS REGULARLY.

**CLEANING:**

DO NOT REMOVE CUSHION COVERS FOR SEPARATE  
CLEANING EVEN THOUGH THEY HAVE ZIPPERS.  
DO NOT WASH  
DO NOT DRY CLEAN  
DO NOT SHAMPOO CLEAN  
CLEAN WITH HOT-WATER EXTRACTION MACHINE.  
(HOT) PROFESSIONAL CLEANING RECOMMENDED  
DO NOT USE DISHWASHING OR LAUNDRY  
DETERGENTS  
USE ONLY UPHOLSTERY DETERGENTS  
DO NOT WET FILLING  
DRY IN SHADE AWAY FROM DIRECT HEAT AND  
SUNLIGHT  
ALLOW TO DRY THOROUGHLY BEFORE RE-USE

**SPOT CLEANING:**

DO NOT RUB  
DO NOT SPOT CLEAN WITH ANY SOLVENT.  
TREAT SPILLS AND STAINS AS SOON AS POSSIBLE.  
GENTLY SCRAPE ANY SOIL OR MOP ANY LIQUID  
FROM THE SURFACE OF THE FABRIC.  
APPLY PROPRIETARY CLEANING AGENTS STRICTLY  
ACCORDING TO INSTRUCTIONS TO REMOVE THE  
RESIDUE OF THE SPILL.  
DO NOT SATURATE THE FABRIC OR INTERIOR WITH  
WATER OR OTHER CLEANING LIQUIDS.

**WARNING:** APPLY ONLY WATER-BASED SOIL RESIST  
(FABRIC PROTECTION) TREATMENTS. DO NOT USE  
AEROSOL PRODUCTS.